



SSCS0520D1

Schottky Barrier Diode

● Features

- ✧ Low Forward Voltage Drop
- ✧ Guard Ring Construction for Transient Protection
- ✧ High Conductance
- ✧ Also Available in Lead Free Version

● PIN configuration



SOD-123

● Applications

- ✧ Low Voltage Rectification
- ✧ High-Efficiency DC-DC Conversion
- ✧ Switch Mode Power Supply
- ✧ Inverse Polarity Protection



Circuit Diagram



Marking

● Absolute maximum rating @T_A=25°C

Parameter	Symbol	Value	Unit
Peak Repetitive Peak Reverse Voltage	V _{RRM}		
Working Peak Reverse Voltage	V _{RWM}	20	V
DC Blocking Voltage	V _R		
RMS reverse voltage reverse voltage (DC)	V _{RMS}	14	V
Average Rectified Output Current	I _O	500	mA
Non-repetitive Peak Forward Surge Current @t=8.3ms	I _{FSM}	5.5	A
Power Dissipation	P _D	500	mW
Typical Thermal Resistance	R _{θJA}	200	°C/W
Operating Temperature	T _J	-40 ~ +125	°C
Storage Temperature	T _{STG}	-50 ~ +150	°C
Voltage rate of change	dv/dt	1000	V/μs



● **Electrical Characteristics @ $T_A=25^{\circ}\text{C}$**

Parameter	Symbol	Conditions	Min.	Typ.	Max.	Unit
Reverse Voltage	V_R	$I_R = 250\mu\text{A}$	20			V
Forward Voltage	V_F	$I_F = 0.1\text{A}$			0.33	V
		$I_F = 0.5\text{A}$			0.39	
Reverse Current	I_R	$V_R = 10\text{V}$			75	μA
		$V_R = 20\text{V}$			250	
Junction Capacitance	C_J	$V_R = 1\text{V}, f = 1\text{MHz}$		170		pF

● **Typical Performance Characteristics**

Forward Characteristics

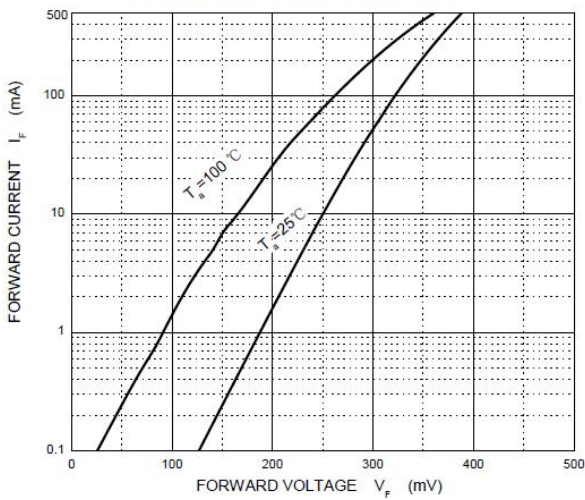

Reverse Characteristics

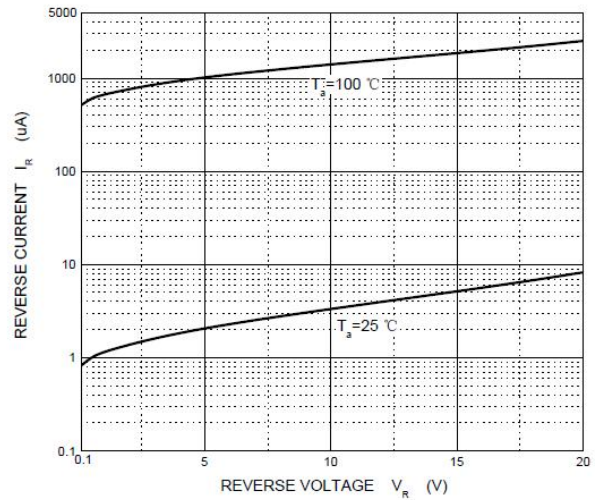

Capacitance Characteristics

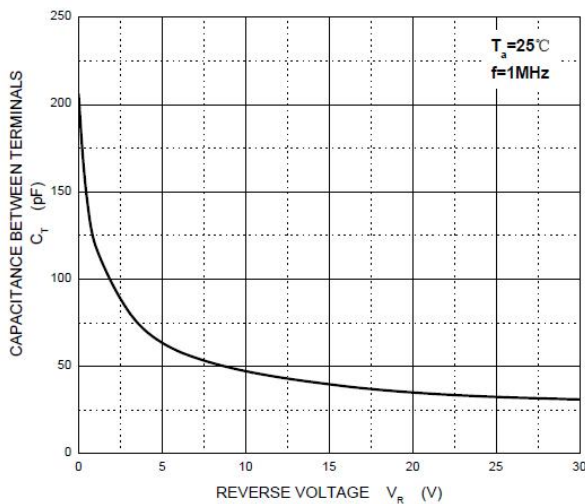

Power Derating Curve

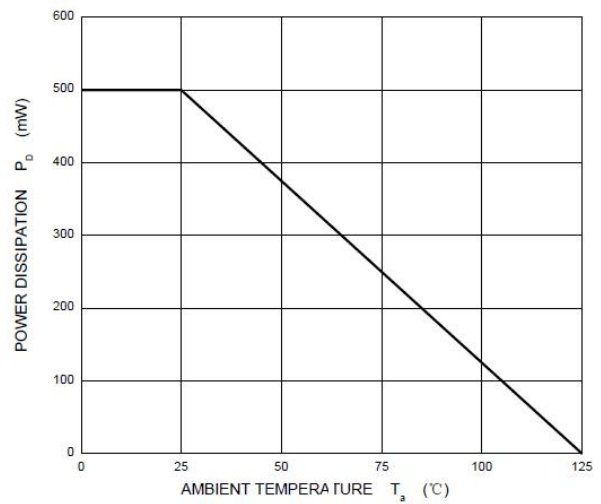



● Package Information

Ordering Information

Device	Package	Marking	Qty per Reel	Reel Size
SSCS0520D1	SOD-123	SD	3000	7 Inch

Mechanical Data

Case: SOD-123

Case Material: Molded Plastic. UL Flammability

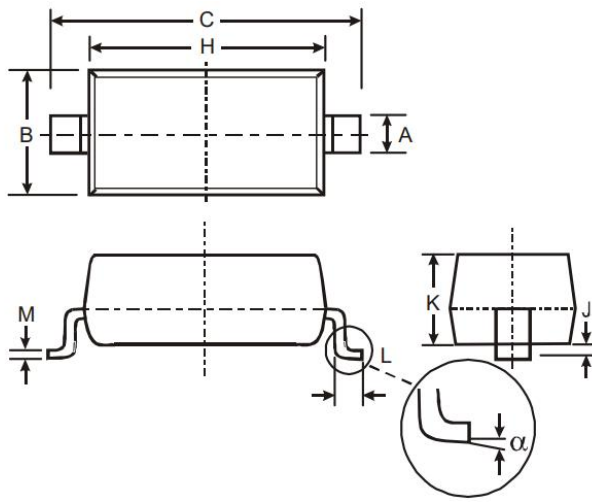

DIM	Millimeters	
	Min	Max
A	0.45	0.65
B	1.50	1.70
C	3.55	3.85
H	2.6	2.8
J	0.00	0.10
K	1.05	1.15
L	0.25	0.45
M	0.08	0.15
α	0	8°

Recommended Pad outline (Unit: mm)

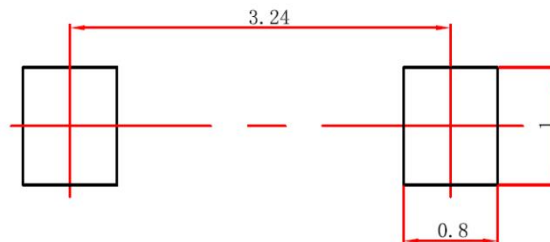



DISCLAIMER

SSCSEMI RESERVES THE RIGHT TO MAKE CHANGES WITHOUT FURTHER NOTICE TO ANY PRODUCTS HEREIN TO IMPROVE RELIABILITY, FUNCTION OR DESIGN. SSCSEMI DOES NOT ASSUME ANY LIABILITY ARISING OUT OF THE APPLICATION OR USE OF ANY PRODUCT OR CIRCUIT DESCRIBED HEREIN; NEITHER DOES IT CONVEY ANY LICIENCE UNDER ITS PATENT RIGHTS, NOR THE RIGHTS OF OTHERS.

THE GRAPHS PROVIDED IN THIS DOCUMENT ARE STATISTICAL SUMMARIES BASED ON A LIMITED NUMBER OF SAMPLES AND ARE PROVIDED FOR INFORMATIONAL PURPOSE ONLY. THE PERFORMANCE CHARACTERISTICS LISTED IN THEM ARE NOT TESTED OR GUARANTEED. IN SOME GRAPHS, THE DATA PRESENTED MAY BE OUTSIDE THE SPECIFIED OPERATING RANGE (E.G. OUTSIDE SPECIFIED POWER SUPPLY RANGE) AND THEREFORE OUTSIDE THE WARRANTED RANGE.

OUR PRODUCT SPECIFICATIONS ARE ONLY VALID IF OBTAINED THROUGH THE COMPANY'S OFFICIAL WEBSITE, CRM SYSTEM, OR OUR SALES PERSONNEL CHANNELS. IF CHANGES OR SPECIAL VERSIONS ARE INVOLVED, THEY MUST BE STAMPED WITH A QUALITY SEAL AND MARKED WITH A SPECIAL VERSION NUMBER TO BE VALID.