



## SSCS5819D1

### Schottky Barrier Diode

#### ● Features

- ✧ Low Forward Voltage Drop (VF)
- ✧ Better Efficiency and Cooler Operation
- ✧ Guard Ring Construction for Transient Protection

#### ● PIN configuration



**SOD-123**

#### ● Applications

- ✧ Low Voltage Rectification
- ✧ High-Efficiency DC-DC Conversion
- ✧ Switch Mode Power Supply
- ✧ Inverse Polarity Protection



**Circuit Diagram**



**Marking(Top View)**

#### ● Absolute maximum rating @T<sub>A</sub>=25°C

Parameter	Symbol	Value	Unit
Non-repetitive Peak Reverse Voltage	V <sub>RM</sub>	40	V
Peak Repetitive Peak Reverse Voltage	V <sub>RPM</sub>		
Working Peak Reverse Voltage	V <sub>RWM</sub>		
DC Blocking Voltage	V <sub>R</sub>		
Average Rectified Output Current	I <sub>O</sub>	1	A
Non-repetitive Peak Forward Surge Current @t=8.3ms	I <sub>FSM</sub>	9	A
Power Dissipation	P <sub>D</sub>	250	mW
Operating Temperature	T <sub>J</sub>	125	°C
Storage Temperature	T <sub>STG</sub>	-40 ~ +125	°C

#### ● Electrical Characteristics @T<sub>A</sub>=25°C

Parameter	Symbol	Conditions	Min.	Typ.	Max.	Unit
Reverse Voltage	V <sub>R</sub>	I <sub>R</sub> = 1mA	40			V
Forward Voltage	V <sub>F</sub>	I <sub>F</sub> = 1A			0.6	V
		I <sub>F</sub> = 3A			0.9	
Reverse Current	I <sub>R</sub>	V <sub>R</sub> = 40V			1	mA
Junction Capacitance	C <sub>J</sub>	V <sub>R</sub> =4V,f=1MHz			120	pF



- Typical Performance Characteristics

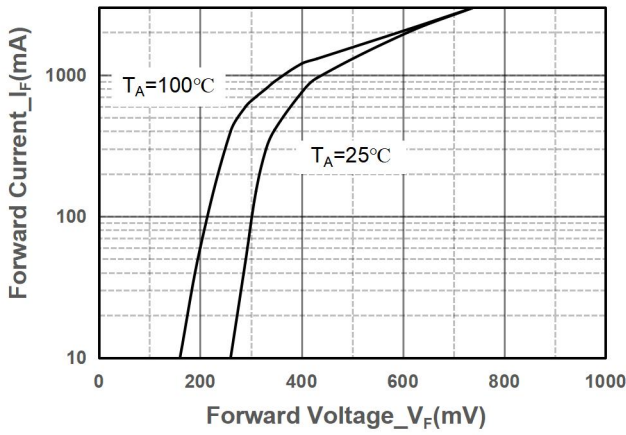

Forward Voltage vs. Forward Current

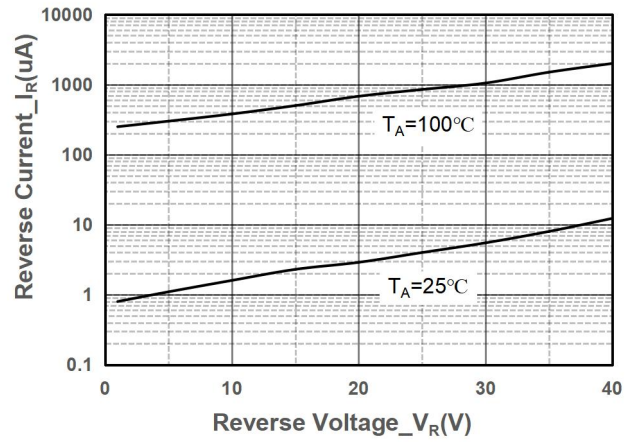

Reverse Voltage vs. Reverse Current

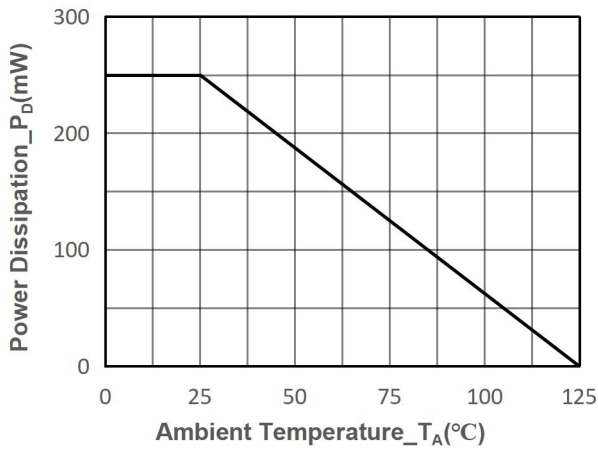

Power Derating vs. Ambient Temperature

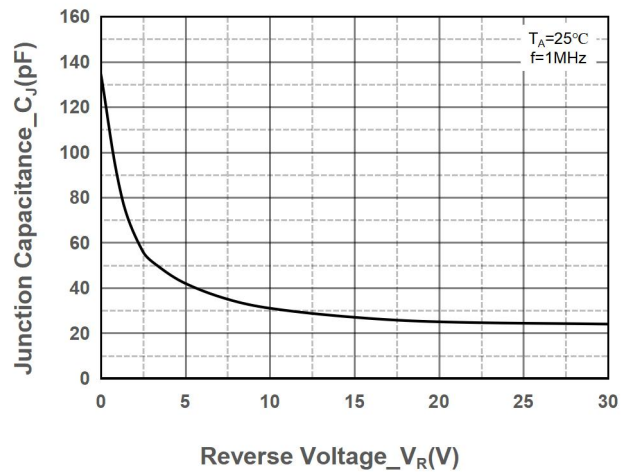

Junction Capacitance vs. Reverse Voltage



## ● Package Information

### Ordering Information

Device	Package	Marking	Qty per Reel	Reel Size
SSCS5819D1	SOD-123	SL	3000	7 Inch

### Mechanical Data

Case: SOD-123

Case Material: Molded Plastic. UL Flammability

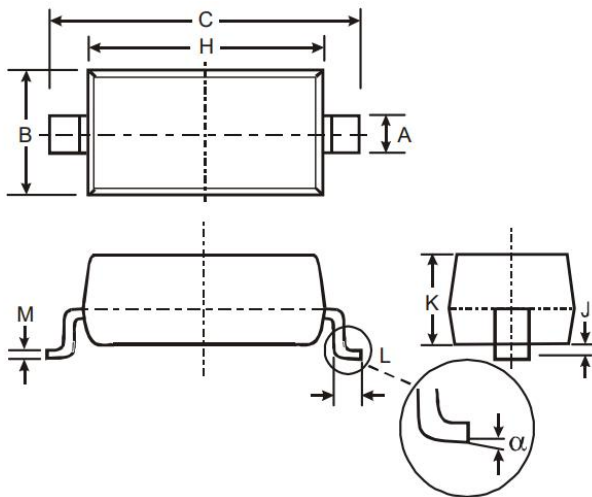

DIM	Millimeters	
	Min	Max
A	0.45	0.65
B	1.50	1.70
C	3.55	3.85
H	2.6	2.8
J	0.00	0.10
K	1.05	1.15
L	0.25	0.45
M	0.08	0.15
$\alpha$	0	8°

### Recommended Pad outline (Unit:mm)

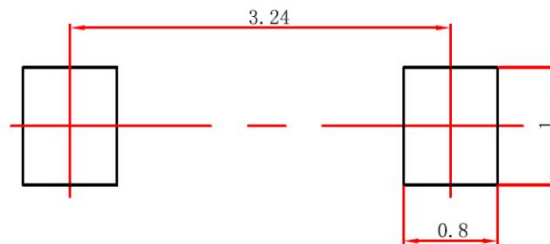



## DISCLAIMER

SSCSEMI RESERVES THE RIGHT TO MAKE CHANGES WITHOUT FURTHER NOTICE TO ANY PRODUCTS HEREIN TO IMPROVE RELIABILITY, FUNCTION OR DESIGN. SSCSEMI DOES NOT ASSUME ANY LIABILITY ARISING OUT OF THE APPLICATION OR USE OF ANY PRODUCT OR CIRCUIT DESCRIBED HEREIN; NEITHER DOES IT CONVEY ANY LICIENCE UNDER ITS PATENT RIGHTS, NOR THE RIGHTS OF OTHERS.

THE GRAPHS PROVIDED IN THIS DOCUMENT ARE STATISTICAL SUMMARIES BASED ON A LIMITED NUMBER OF SAMPLES AND ARE PROVIDED FOR INFORMATIONAL PURPOSE ONLY. THE PERFORMANCE CHARACTERISTICS LISTED IN THEM ARE NOT TESTED OR GUARANTEED. IN SOME GRAPHS, THE DATA PRESENTED MAY BE OUTSIDE THE SPECIFIED OPERATING RANGE (E.G., OUTSIDE SPECIFIED POWER SUPPLY RANGE ) AND THEREFORE OUTSIDE THE WARRANTED RANGE.

OUR PRODUCT SPECIFICATIONS ARE ONLY VALID IF OBTAINED THROUGH THE COMPANY'S OFFICIAL WEBSITE, CRM SYSTEM, OR OUR SALES PERSONNEL CHANNELS. IF CHANGES OR SPECIAL VERSIONS ARE INVOLVED, THEY MUST BE STAMPED WITH A QUALITY SEAL AND MARKED WITH A SPECIAL VERSION NUMBER TO BE VALID.